

Clarification tank equipment for prevention instead of cure

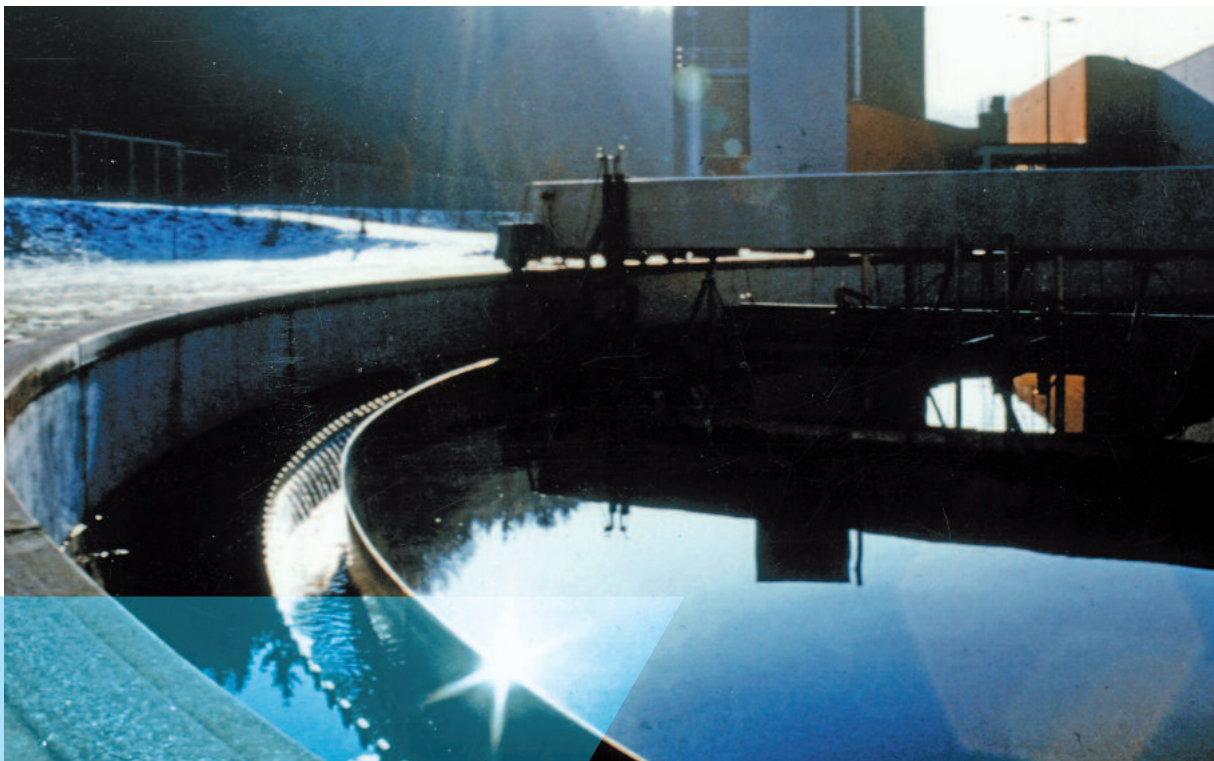

Corrosion-resistant and maintenance-free stainless steel products for new constructions and refurbishing of clarification tanks

➤ Our range of products:

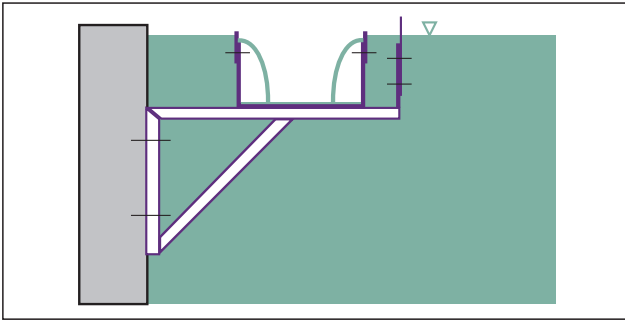

Ablaufrinne KA 1 – Überfall beidseitig mit vorgesetzter Tauchwand
Ablaufrinne KA 2 – Überfall einseitig

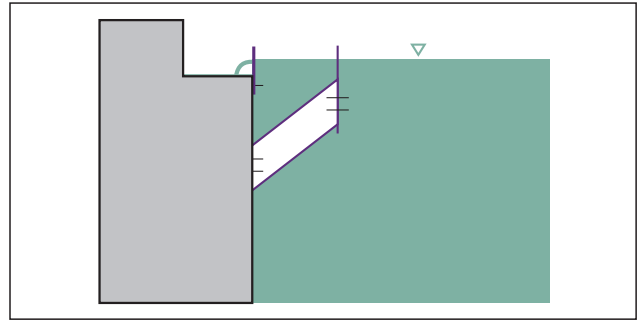

Baffle KA 3
 on concrete sleeper

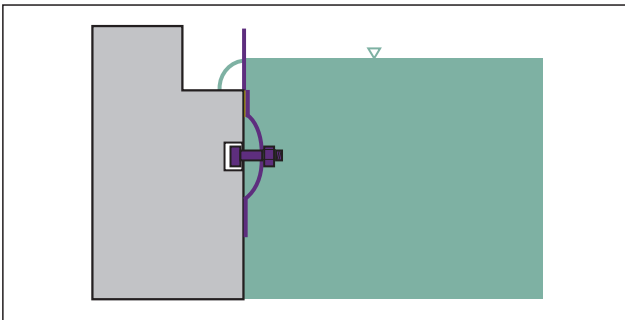

Overflow weir KA 4

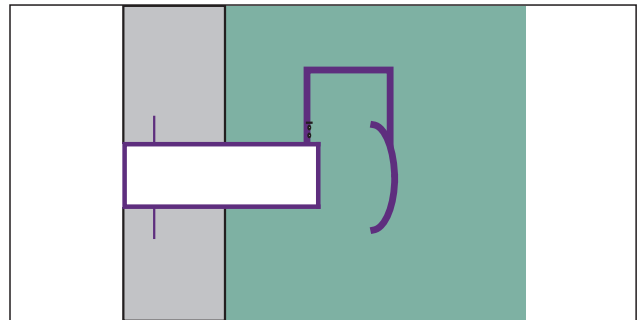

Stengel-type inlet KA 5

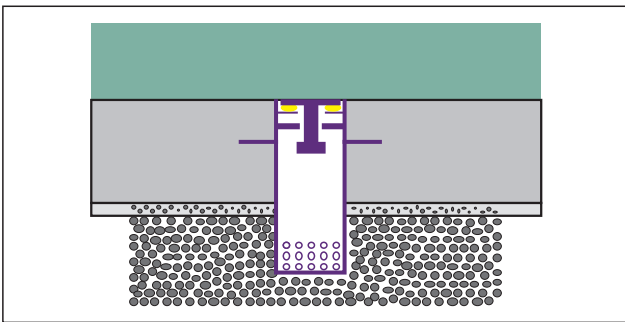

Groundwater flap valve KA 6

Covering for tank heads

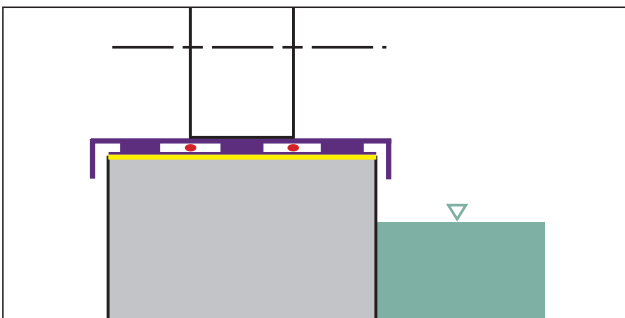

With heating tapes, see separate brochure.

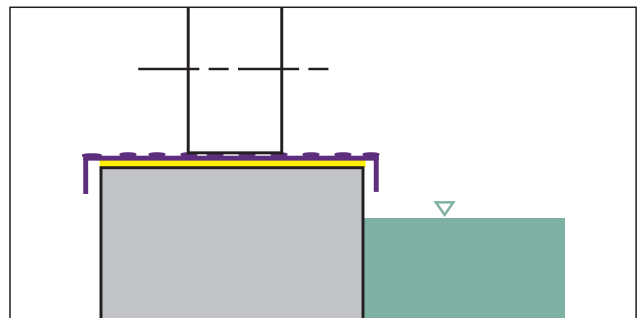

Without heating tapes KA 10 and KA 11, see separate brochure.

➤➤ This can be avoided:

Before renovation

Components installed in sewage treatment plants are especially susceptible to corrosion where in contact with wastewater. The requirements on materials are high due to aggressive salts. Electrochemical decomposition is especially high in the area where the atmosphere meets the wastewater. Inappropriate materials, such as aluminium, black or galvanized steel show a loss of material thickness before breaking down completely.

The dentated sill in the picture shows both perforations and irregular abrasion with the result of irregular clarified water discharge.



After renovation

Only about 5 % of the total investment costs for a STW are spent on installed components. Maintenance costs amount to approx. 60 % of the total maintenance expenditure. It is therefore necessary to make sure from the beginning that the right material is chosen. With expert processing of the material, stainless steel products guarantee:

- Durability
- No maintenance requirements
- Prompt availability
- Reliable operation
- Extremely high corrosion resistance



➤➤ Expert processing of stainless steel

HUBER clarification tank equipment meets any requirements::

- Expert installation by the manufacturer's fitters
- Individually calculable inlet and outlet systems for optimal efficiency
- Advisory service backed by decades of practical experience

HUBER stainless steel products are the perfect solution for municipal and industrial wastewater treatment applications. Whatever the requirement, stainless steel is the material which satisfies the highest demands:

- Long life
- Complete corrosion protection from pickling bath and passivation
- Standard product range for simple planning and competitive price
- For coverings for tank heads and submerged pipes see separate brochure.

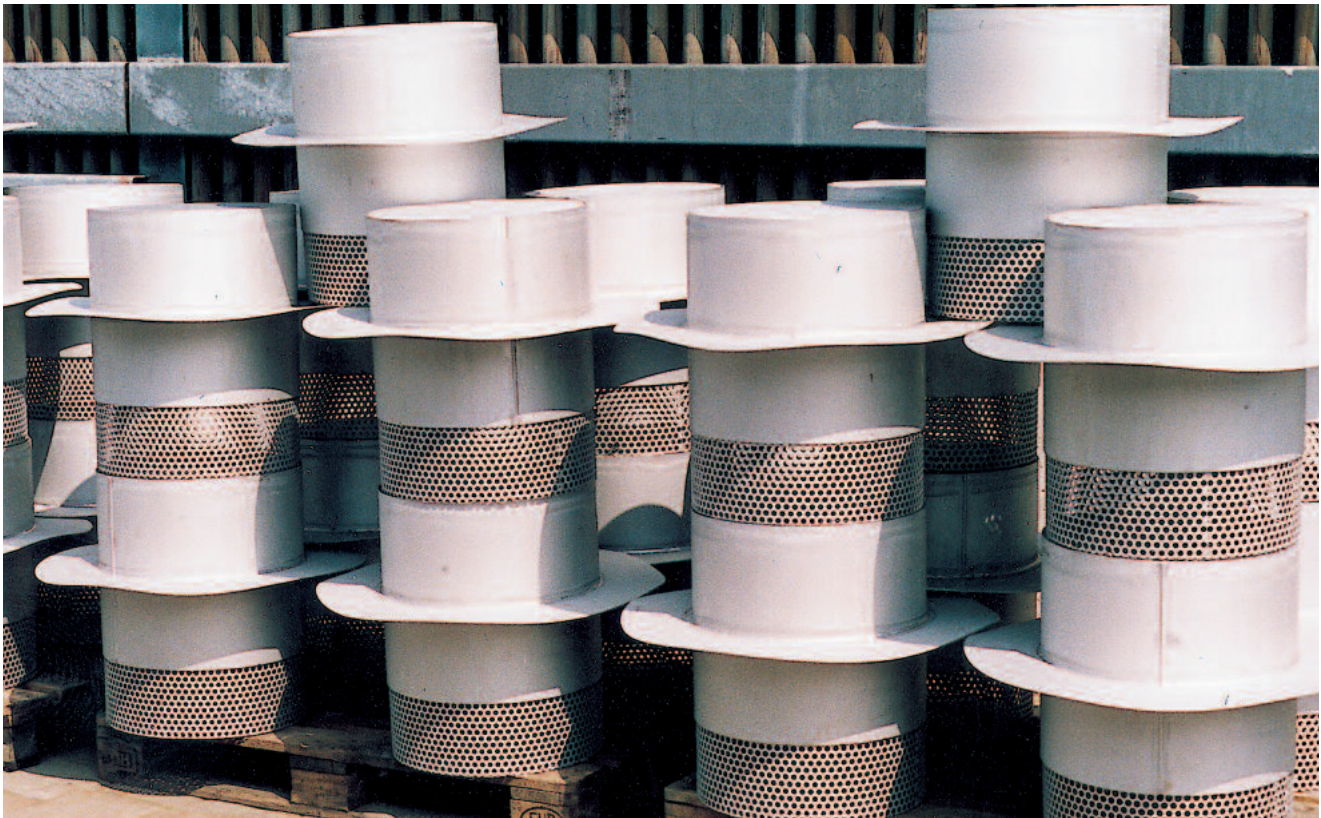

HUBER SE

Industriepark Erasbach A1 · D-92334 Berching
Phone: + 49 - 84 62 - 201 - 0 · Fax: + 49 - 84 62 - 201 - 810
info@huber.de · Internet: www.huber.de

Subject to technical modification
0,05 / 3 – 8.2010 – 11.2004

PG 7 Clarification Tank Equipment