

HUBER Grit Treatment System RoSF 5VW(S)



Treatment of grit from wastewater treatment plants and sewer systems by means of a Wash Drum / Grit Washer

- Loss on ignition of the grit/gravel fraction < 3%
- Coarse material separation size of 10 mm
- Reduced disposal costs



➤➤ Grit Treatment System RoSF 5VWS (with treatment of circulation)

Acceptance station with dosing screw



Acceptance tank with bar grate and integrated vertical dosing screw

Untreated sewer grit



Grit trap



Untreated grit from STPs

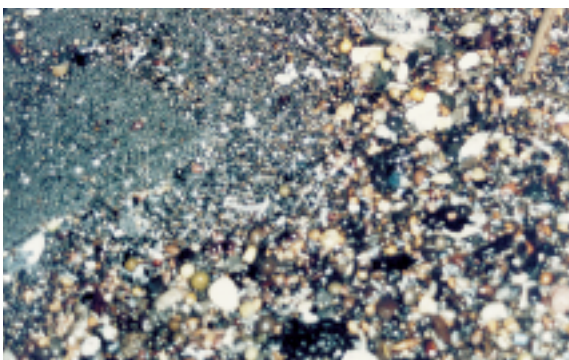

acceptance tank with vertical dosing screw

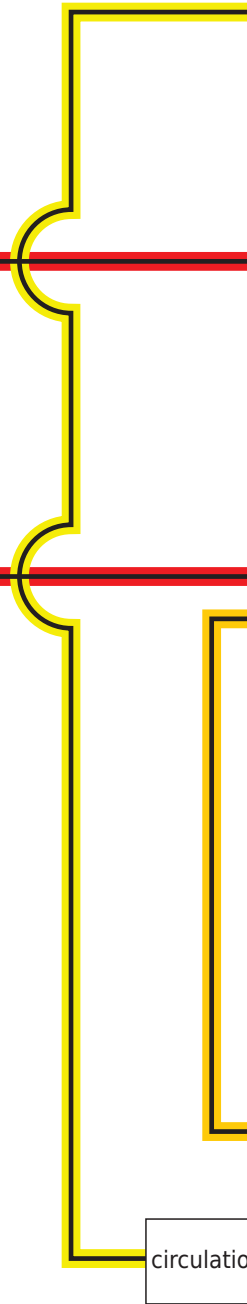
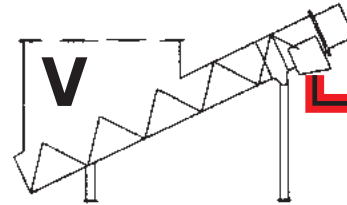

Maximum hydraulic capacity [l/s]
Maximum solids throughput (per wash)
Drive capacity [kW] (depending on the)
Dimensions

water)

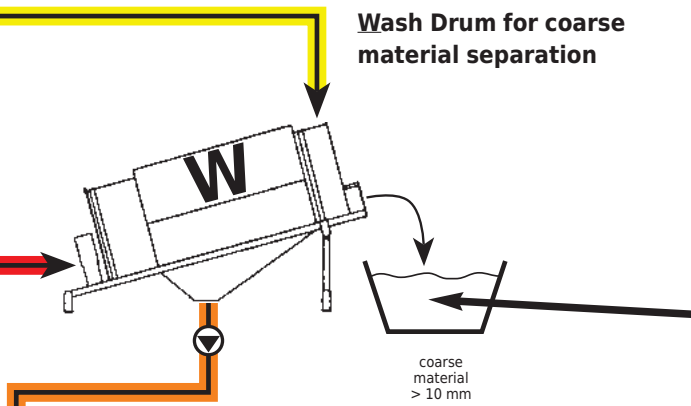

Coarse material separation



ROTAMAT® Wash Drum for washout and separation of all coarse material > 10 mm

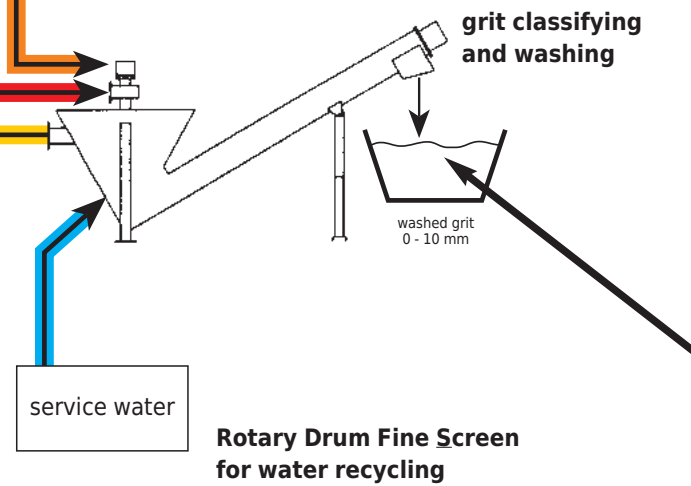

Grit classifying and washing



Washed grit from COANDA Grit Washer with < 3% loss on ignition, particle size up to 10 mm, DR > 90%

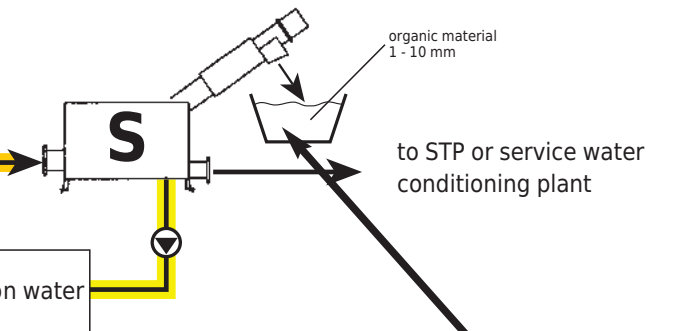

Circulation water conditioning



ROTAMAT® fine screen for 1 mm screening and dewatering of organic material (approx. 30% DR)

	25
cycle [m³/h]	3
process type)	10-30
	upon request

►► Design and function

Acceptance station with vertical dosing screw

After discharge of the liquid phase into the STP inlet the sewer cleaning vehicle empties the solids into the intermediate storage tank. A discharge unit will later remove the water introduced, if any (from the vehicle, or stormwater, or wash water). A vertical (inclined) dosing screw installed within the tank removes the solids and doses them into a subsequent Wash Drum.

Coarse material separation

While wash water is added to pre-wash and homogenise the raw material within the Wash Drum, the perforated plate of the Wash Drum retains all particles > 10 mm, which are dewatered and then discharged into a skip. Since only coarse material > 10 mm is separated, the volume of the resultant residues is vastly reduced with the complete mineral material being further treated. The resultant coarse material can then be further separated into a mineral and organic fraction by means of a coarse material washer.

Grit classifying and washing

The grit/gravel/organics/water mixture is collected within a sump under the ROTAMAT® Wash Drum and is then pumped into the COANDA Grit Washer. With the use of the COANDA effect the rotational flow is directed to the tank where a defined flow field is produced which creates optimum conditions for the separation of mineral components. Due to a defined introduction of upwardly directed service water the grit situated within the lower part of the COANDA Grit Washer is fluidised within the flow enabling the lighter organic particles to be separated from the dense grit particles. The mineral fraction cleaned from organic components (grit and gravel up to 10 mm grain size, < 3% loss on ignition) is then automatically discharged by the integral grit removal screw when it is then statically dewatered and discharged into a container. The material can thereafter be recycled or dumped on inert material landfills.

Conditioning of circulation water

The complete effluent from the COANDA Grit Washing Plant is passed into a Rotary Drum Fine Screen which then separates all organic material > 2 mm and discharges the dewatered material into a skip and the resultant screened organic material can then normally be either composted or incinerated. The screened water can be used as wash and transport water for the ROTAMAT® Wash Drum. A pump situated after the Rotary Drum Fine Screen delivers the water to the spray nozzles within the Wash Drum. And any excess water is passed on to the wastewater treatment facility (STW or separate water conditioning facility). The circulation of the resultant water minimises water consumption and achieves excellent separation degrees of fine grit.

►► System options available

- Reuse and circulation of the complete water is possible.
- Additional treatment of coarse material is possible.
- Separation of the fine gravel fraction by classification with a subsequent screen
- Further treatment of the mineral fraction by agitation
- Integration of an additional process stage to increase the separation efficiency of fine grit up to 0.1 mm
- Possibility of complete service and wash water conditioning with integrated sludge treatment

►► The user's benefits

- Reduction of organics in the grit/gravel fraction to < 3% loss on ignition
- Reduction in disposal volumes and costs
- Maximum minerals yield
- > 95% capture rate of 0.20 – 0.25 mm diameter grit particles
- Coarse material separation size of 10 mm
- Allows for reuse of the mineral material
- Manufactured entirely of stainless steel for maximum corrosion resistance

Hans Huber AG

Phone: + 49 - 84 62 - 201 - 0

Subject to technical modification

Telefax: + 49 - 84 62 - 201 - 810

Maschinen- und Anlagenbau
Postfach 63 · D-92332 Berching

E-mail: info@huber.de

Internet: www.huber.de

**HUBER Grit Treatment
System RoSF 5VW(S)**